

Li-ion building block with LG HE2 datasheet

RoHS
Compliant



FEATURES

- Small size: 197-343 Wh per liter
- Low weight: 161-168 Wh per kg
- Individually fuse-protected cells
- Ultra low and equal self-discharge
- Rapid prototyping of battery pack
- Convenient thermal control
- Built-in temperature sensors
- UL94-V0 rated, fire-retardant plastics
- UN38.3 certified

APPLICATIONS

- Performance electric vehicles
- Special purpose machines
- Backup energy storage

INTRODUCTION

A Li-ion building block was developed with simplicity and safety in mind. Using 18650 lithium-ion technology, such building blocks offer the most modern and energy-dense solution in easy to use package. 18650 is a very well established and time-tested battery cell standard, especially common in consumer devices. These cells are designed to withstand consumer’s rough treatment, while offering the best in class energy density.

SAFETY

In addition to internal protection techniques, the module includes two fuses for each cell. These act as a second level protection devices in case of cell failure. In case of cell venting, released gas is travelled through dedicated channels to avoid pressure buildup.

FLEXIBILITY

Due to simple nature of these building blocks, desired battery pack configuration can be built in minutes, connecting them in series and parallel using bolt connections. Even MWh-scale batteries can be assembled with ease.

Table 1: Working temperature

	Min.	Typ.	Max.
Discharge	-20 °C	25 °C	60 °C
Charge	0 °C	25 °C	45 °C

Table 2: Product characteristics (all parameters rated at 22°C if not specified otherwise)

Module	Battery voltage (V)			Battery capacity (A)		Fast charge current (A)	Discharge current (A)*1	Initial internal impedance (mΩ)*2	Internal fuse rating (A) (mΩ)*3
	Min.	Typ.	Max.	Ah	Wh	Max.	Max.	Typ.	Typ.
Li1x1pHE2	2.5	3.6	4.2	2.5	9	4	20	16.9	45
Li1x2pHE2				5	18	8	40	8.9	90
Li1x3pHE2				7.5	27	12	60	5.9	135
Li1x4pHE2				10	36	16	80	4.6	180
Li1x5pHE2				12.5	45	20	100	3.7	225
Li1x6pHE2				15	54	24	120	3.1	270
Li1x7pHE2				17.5	63	28	140	2.6	315
Li1x8pHE2				20	72	32	160	2.3	360
Li1x9pHE2				22.5	81	36	180	2.1	405
Li1x10pHE2				25	90	40	200	1.9	450
Li2x1pHE2				5	18	8	40	8.0	90
Li2x2pHE2				10	36	16	80	4.1	180
Li2x3pHE2				15	54	24	120	2.8	270
Li2x4pHE2				20	72	32	160	2.1	360
Li2x5pHE2				25	90	40	200	1.7	450
Li2x6pHE2				30	108	48	240	1.5	540
Li2x7pHE2				35	126	56	280	1.3	630
Li2x8pHE2				40	144	64	320	1.1	720
Li2x9pHE2				45	162	72	360	1.0	810
Li2x10pHE2				50	180	80	400	1.0	900

*1 - With 80 deg temperature cutoff. *2 - Measurements are done with B&K Precision BA6010 device. *3 - Approximately.

DISCHARGE CHARACTERISTICS

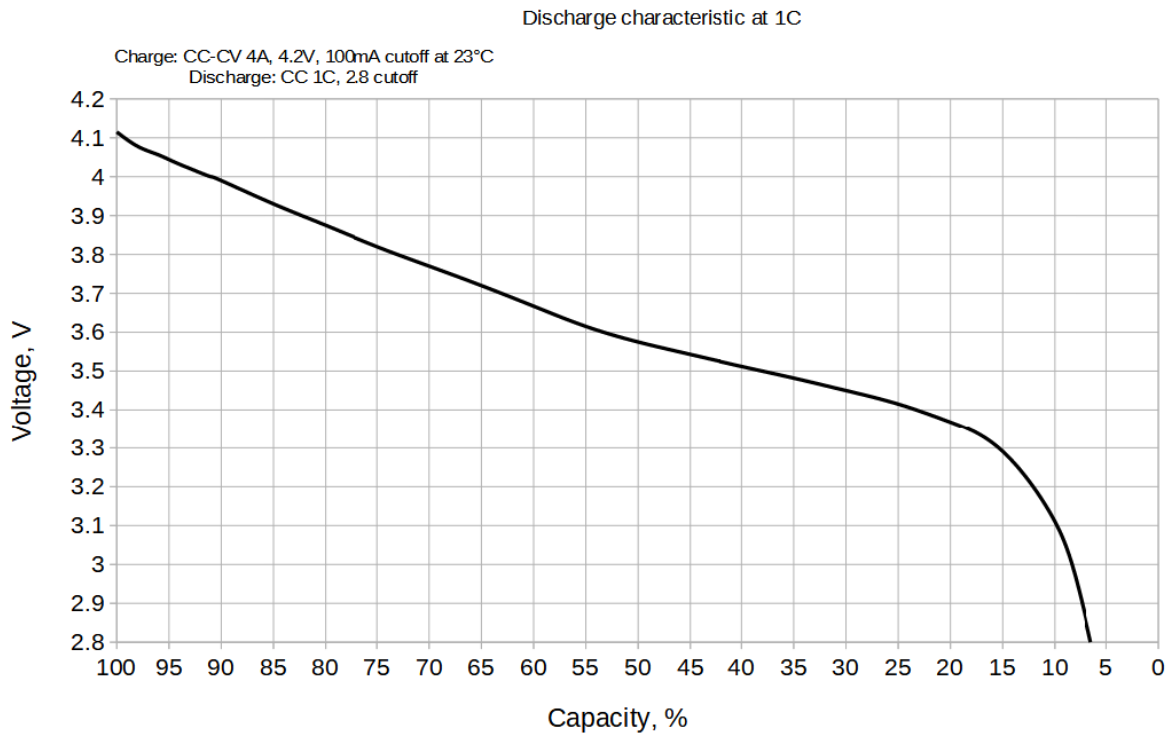

Figure 1: A typical discharge slope at 1C rate.

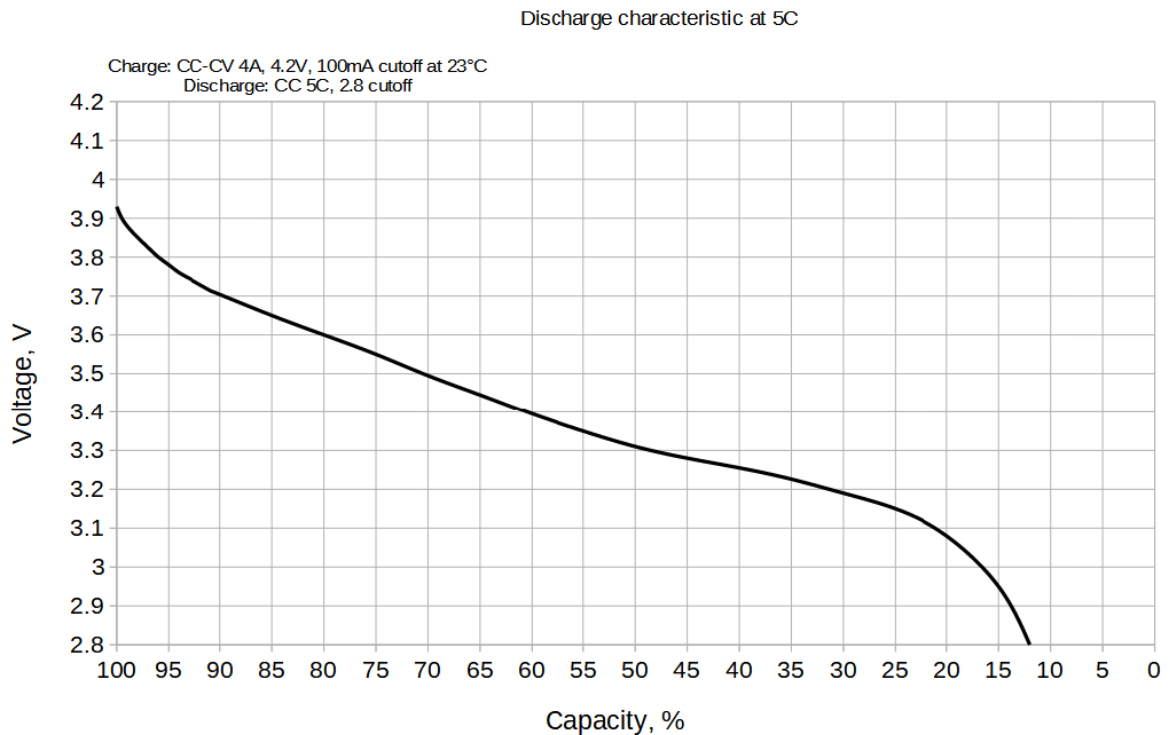

Figure 2: A typical discharge slope at 5C rate.

Test current	Measured energy (Wh)
1C	8.588
5C	7.725

Table 3: Measured energy at different load.

TEMPERATURE SENSOR

The module has a temperature sensor built in, which meets and exceeds safety requirements of FSAE 2017 regulations. Each one of the sensors is in physical contact with negative pole of two adjacent cells and provides very fast temperature measurement response. Such construction provides inexpensive monitoring of all 100 % of cells ($\geq 30\%$ is required by FSAE).

Innovative analogue signal OR'ing technique allows all sensor signals to be read with two-wire acquisition system: output acts as a hot spot detector and reports only the maximum temperature. When battery is operating within safe limits, all sensors report similar temperatures and such measurement accurately represents overall temperature of the module. However, in case of failure event, hot spot is very quickly noticed.

The sensor is a special-made temperature-variable voltage shunt reference. In simple words, it acts as a zener diode, whose voltage drop depends on temperature. It requires a pull-up resistor (680Ω) to operate at cell voltage level. For convenience, the module can be used to power the sensor as given in test circuit in Figure 4.

The signal is non-linear, as given in Figure 5 below. It is compensated internally to provide flattest possible curve in operating range of $-40\dots+120^\circ\text{C}$. For convenience, conversion values are given in Table 2. Linear interpolation can be used to calculate more values with reasonable accuracy.

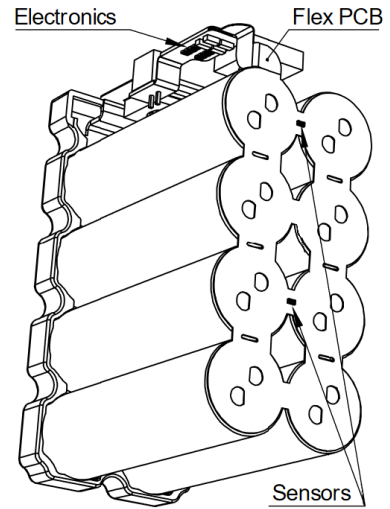

Figure 3: Sensor layout.

Table 4: Sensor quantity for modules

Module	1x1	1x2	1x3	1x4	1x5	1x6	1x7	1x8	1x9	1x10
Qty	0	1	1	2	2	3	3	4	4	4
Module	2x1	2x2	2x3	2x4	2x5	2x6	2x7	2x8	2x9	2x10
Qty	1	1	2	2	2	3	3	4	4	4

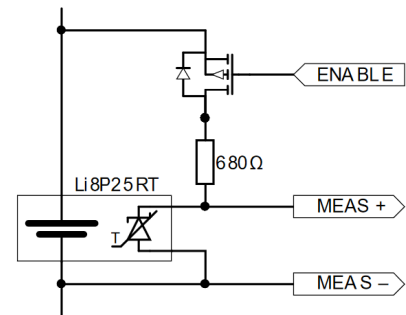

Figure 4: Test circuit.

Table 5: Voltage-to-temperature conversion values

Temp, °C	-40	-35	-30	-25	-20	-15	-10	-5	0	5	10	15	20	25	30	35	40
V_{out}, V	2.44	2.42	2.40	2.38	2.35	2.32	2.27	2.23	2.17	2.11	2.05	1.99	1.92	1.86	1.80	1.74	1.68
Temp, °C	45	50	55	60	65	70	75	80	85	90	95	100	105	110	115	120	
V_{out}, V	1.63	1.59	1.55	1.51	1.48	1.45	1.43	1.40	1.38	1.37	1.35	1.34	1.33	1.32	1.31	1.30	

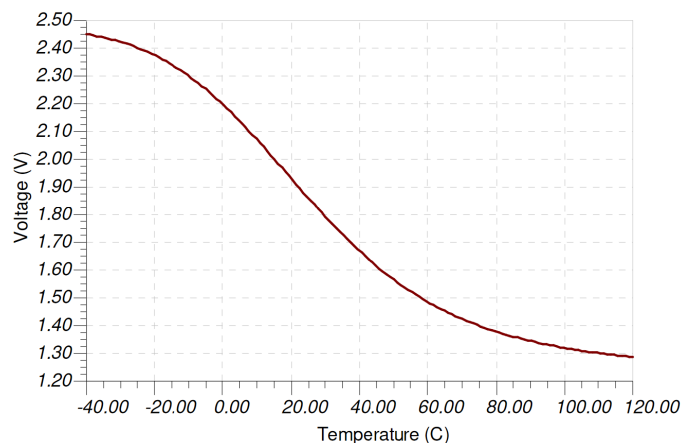

Figure 5: Temperature-Voltage response.

Temperature sensor is galvanically isolated from cell terminals and signal can be safely read with separate circuit. However, it is very convenient to use a standard stack measurement ICs, usually used for battery monitoring and balancing. A circuit example with widely available LTC6803 is given in Figure 6.

To measure temperature, balancing switch is activated on the IC. After doing so, voltage difference between Cn+1 and Cn represents temperature. During such measurement, sensor current flows from cell positive tab through series resistor to sensor, then to internal balancing FET of IC, and then to cell negative via another series resistor. Thus 330Ω resistors are used to form a total of 680Ω resistance for the sensor in this case.

When switch is disabled, cell voltage can be measured. Note that extra care should be taken when adding capacitors for filtered measurement as this could lead to overcurrent condition in the sensor. Also note that adjacent balancing switches must not be enabled as this would also lead to overcurrent condition. If such technique is chosen, measurements should be done in two cycles, on every second cell at a time (for example: 1, 3 and 5, then 2, 4 and 6).

It is recommended to use separate ICs for battery management and temperature measurement, however, with extra care and smart engineering it is possible to use a single IC for cell voltage measurement, temperature measurement and balancing: cells can be bleed-balanced during temperature measurement if additional bleed resistor and MOSFET is added.

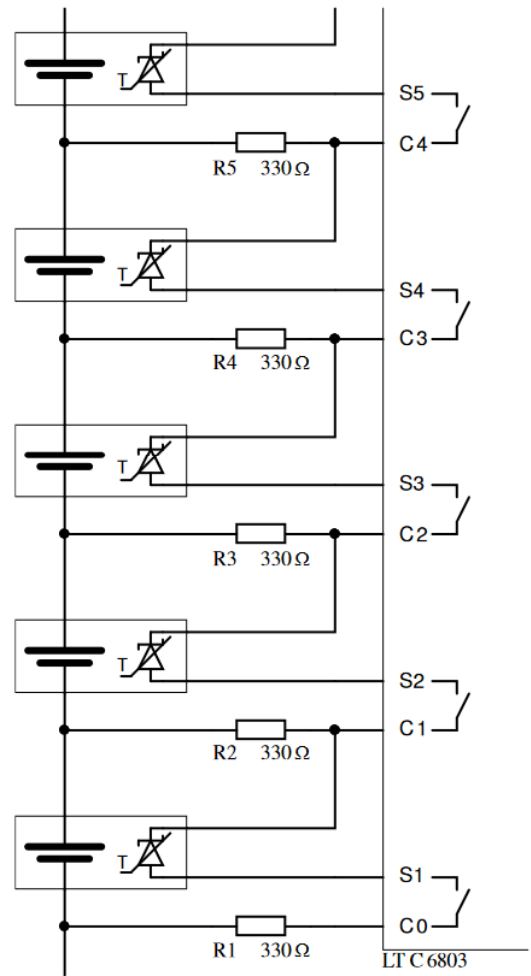

Figure 6: Suggested stack temperature acquisition circuit (simplified).

Table 6: Sensor characteristics (all parameters rated at 25°C if not specified otherwise)

Parameter	Comment	Min.	Typ.	Max.	Unit.
Supply voltage	$V_{min} = V_{cc} - V_{out}$	10	20	-	mV
	When T = -40°C	1.21	1.24	-	V
Forward current	$I_{reg} = \frac{V_{cc} - V_{out}}{R}$	0.40	1	15	mA
Leakage current	When $V_{cc} < V_{out}$	-	5	400	nA
Measurement range	$V_{cc} > 2.5V$	-40	-	120	°C
Isolation	From cell terminals	-	-	60	V

MECHANICAL DATA

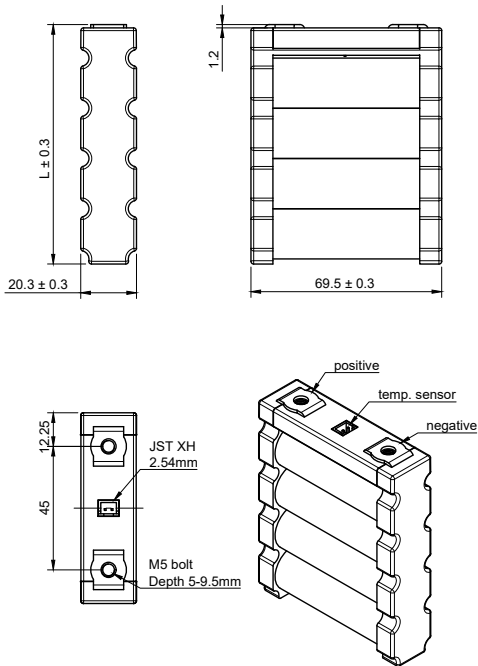

Figure 7: Mechanical dimensions of 1xNp modules

A simplified 3D STP model is available upon request.
1xNp notes:

1. Inner M5 nut is stainless steel
2. Tightening torque: 6 Nm
3. Self-locking washers recommended
4. Modules should be mounted in a firm enclosure to avoid mechanical damage
5. Modules should be protected from direct water ingress
6. Temperature sensor connector: JST XH series

Module	L (mm) ±0.3	Weight* (g)
1x1	32.4	56
1x2	50.7	107
1x3	69.0	158
1x4	87.3	210
1x5	105.6	263
1x6	123.9	315
1x7	142.2	368
1x8	160.5	420
1x9	178.8	473
1x10	195.7	525

*-Without fasteners

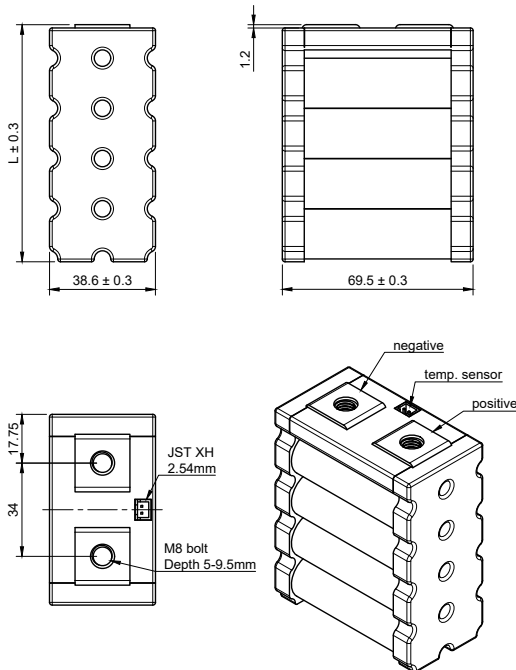

Figure 8: Mechanical dimensions of 2xNp modules

2xNp notes:

1. Inner M8 nut is stainless steel
2. Tightening torque: 10 Nm
3. Self-locking washers recommended
4. Modules should be mounted in a firm enclosure to avoid mechanical damage
5. Modules should be protected from direct water ingress
6. Temperature sensor connector: JST XH series

Module	L (mm) ±0.3	Weight* (g)
2x1	31.5	107
2x2	49.8	214
2x3	68.1	321
2x4	86.4	428
2x5	104.7	535
2x6	123.0	642
2x7	141.3	749
2x8	159.6	856
2x9	177.9	963
2x10	195.7	1070

*-Without fasteners

TERMS OF USAGE

1. Storage conditions

Module should be stored within a range of temperatures specified as below: Store the battery at 0 ~ 23°C, low humidity (below 65%), no dust and no corrosive gas atmosphere. Otherwise, it may cause loss of performance characteristics, leakage and/or rust.

2. Long-term storage

2.1 If long-term (but not longer than Warranty Period) storage is necessary, Module shall be stored at shipping voltage, because storage with higher voltage may cause more loss of performance characteristics.

2.2 All devices or components connected to module clamps must be disconnected, preventing current leak from module.

2.3 Enepaq shall not be liable for any defects of module after Warranty Period even if Module is stored in accordance with Sections above.

3. Warranty

Enepaq warrants that Module will be free from defects in manufacturing for a period of 12 months from the date of shipping (“Warranty Period”). In case of defects, Enepaq will only replace the affected modules. However, Enepaq shall not be liable for if:

3.1 The buyer undertakes to check the received goods immediately after receiving the goods. If the Buyer receives the order and notices any quality issues or discrepancies, he must notify the Seller in writing within 7 days from receiving the order. In case of concealed defects, the Buyer must notify the Seller within the warranty term, but always within 7 days from noticing the defect.

3.2 Module was improperly installed, repaired, altered or otherwise modified (other than by Enepaq)

3.3 Module was subjected to misuse, abuse, negligence or accident

3.4 Module was used, handled, stored, sold or distributed in a manner contrary or inconsistent to the handling /use instructions provided in this product specification sheet.

4. Application

4.1 The products do not have required certification for aircraft use (any type of aircrafts, drones, planes or other flying, gliding or hovering mechanisms, contraption, devices or other objects) and Enepaq can not be held liable for any damage incurred if the modules are used in such applications. The Buyer takes their own risk for any damages resulting from such use or misuse.

4.2 The Seller does not undertake to indemnify the Buyer of any loss or expenses which are caused by misguided use of Products.

5. Usage

5.1 The Buyer is exclusively responsible for the installation, storage, operation and maintenance of the Goods. The Buyer must ensure that the personnel installing and operating the Goods has appropriate qualifications entitling the personnel to provide handling services with respect to the Goods (including toxic, flammable). The Buyer carries out the installation, storage, operation, maintenance of the Goods, personnel training at its own risk and expense.

5.2 The Seller is not liable for defects in the Goods or inconsistencies of the Goods with the Order if they occurred after the transfer of the Goods to the Buyer due to failure of the Buyer and/or the Buyer’s staff to ensure proper installation, storage, operation within specified limits, maintenance of the Goods or due to the fault of third parties or force majeure or other similar circumstances.

Additional notes: *This product is made to order and is non-cancelable and non-returnable (NCNR) and once the order is placed with the factory no changes may be made.*

Table 7: Revision history

Revision	Date	Description
A	2021-10-26	Initial Release.
B	2022-03-24	Company rebranded to Enepaq.
C	2023-09-06	Edited discharge graphs. Added table 3: Measured energy at different load. Added section "Terms of usage"